

XOMOX[®]

brands you trust.

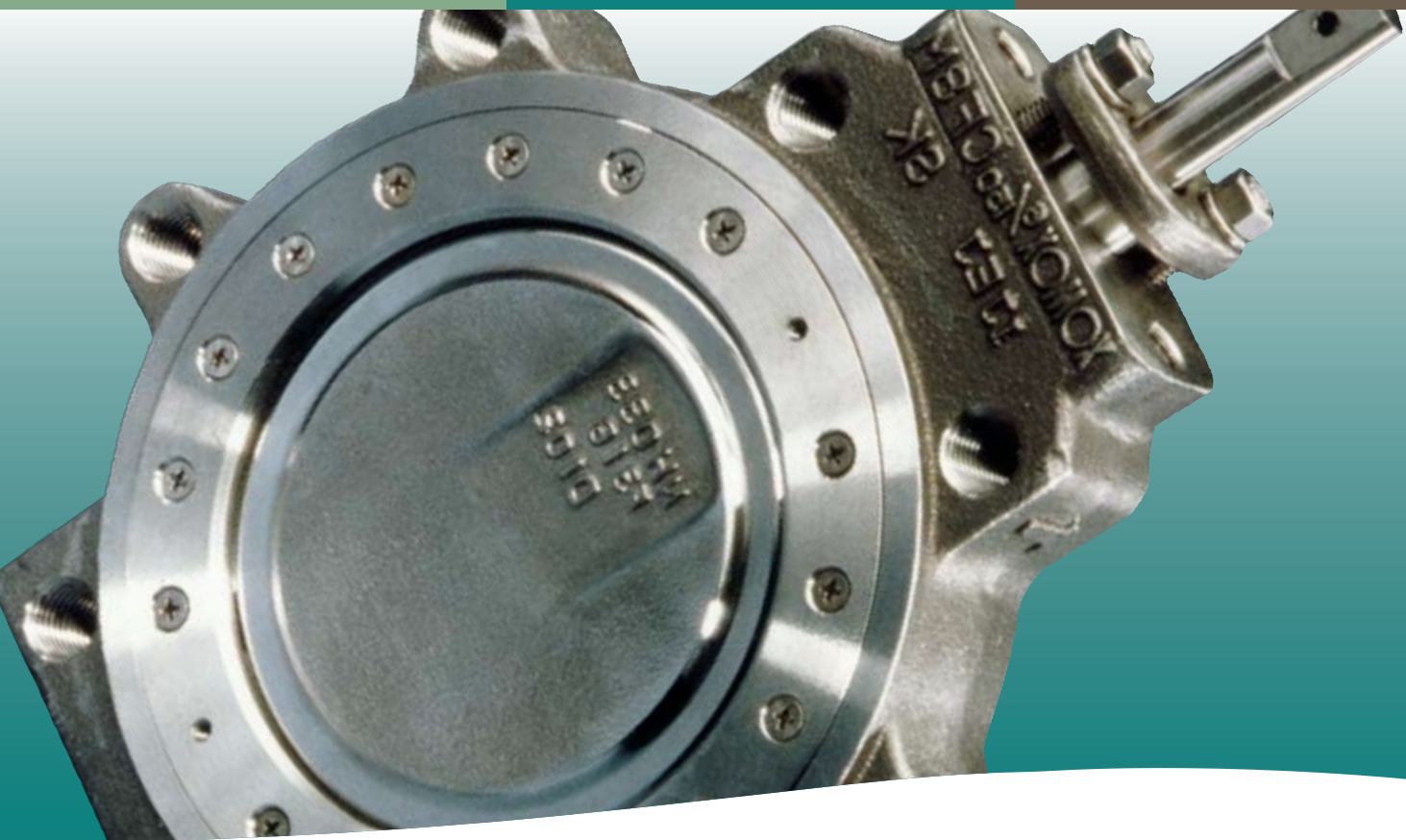

Tuflin[®] High Performance Butterfly Valves 30" - 48" Technical Data

CRANE

ChemPharma Flow Solutions

www.cranepharmasolutions.com

Unique Valve Seat Designs

Xomox is one of the world's leading manufacturers of high performance butterfly valves. Based on many years of research, development and field experience, the TUFLINE design is superior to and more versatile than the High Performance Butterfly Valve design offered by other manufacturers.

The TUFLINE Soft Seat valve provides a bi-directional bubble tight shutoff (zero leakage) by the use of a patented seat. This unique seat design creates a self-energized seal in vacuum-to-low pressure applications. Under higher pressure conditions, the seat is also designed to permit, confine and direct movement of the soft seat against the disc edge, up to the full ANSI Class 150 and 300 cold working pressures. The Soft Seat is designed for service with minimal wear and low torque. Seat replacement is a simple operation, requiring no special tools.

The TUFLINE metal-to-metal seated high performance butterfly valve incorporates an Inconel seat for higher tensile strength, a 300 series stainless steel back-up ring in the seat cavity for axial seat support, and a disc that is case hardened by nitriding. The Inconel seat, by its dynamic and flexible design, applies enough force per linear inch against the disc edge (Rockwell Hardness of C66 to C70) to obtain an optimum sealing characteristic while controlling the loads between the metal surfaces. The TUFLINE metal-to-metal seat valve is utilized for temperatures up to 900°F, in compliance with ANSI B16.34 pressure/temperature specifications. Leakage is rated at Class IV per ANSI FCI 70-2.

The TUFLINE fire tested high performance butterfly valve design incorporates two patented seats which function together to seal off pipeline flow. In normal operation, the soft seat provides a bi-directional "bubble tight" shutoff (zero leakage); the metal seat provides bi-directional shutoff in the event of a fire, in conformance to industry fire-safe requirements. With little or no pressure, the fire tested seat creates a self-energized seal against the disc. Higher line pressures act on the geometry of both seats to dynamically load them against the disc, creating higher sealing forces in either direction. The fire tested metal seat is made of Inconel material which is shaped by a proprietary hydroforming process into its unique, patented design. Stainless steel outer bearings are included for post-fire disc and shaft alignment. Fireproof packing is used to prevent external shaft leakage.

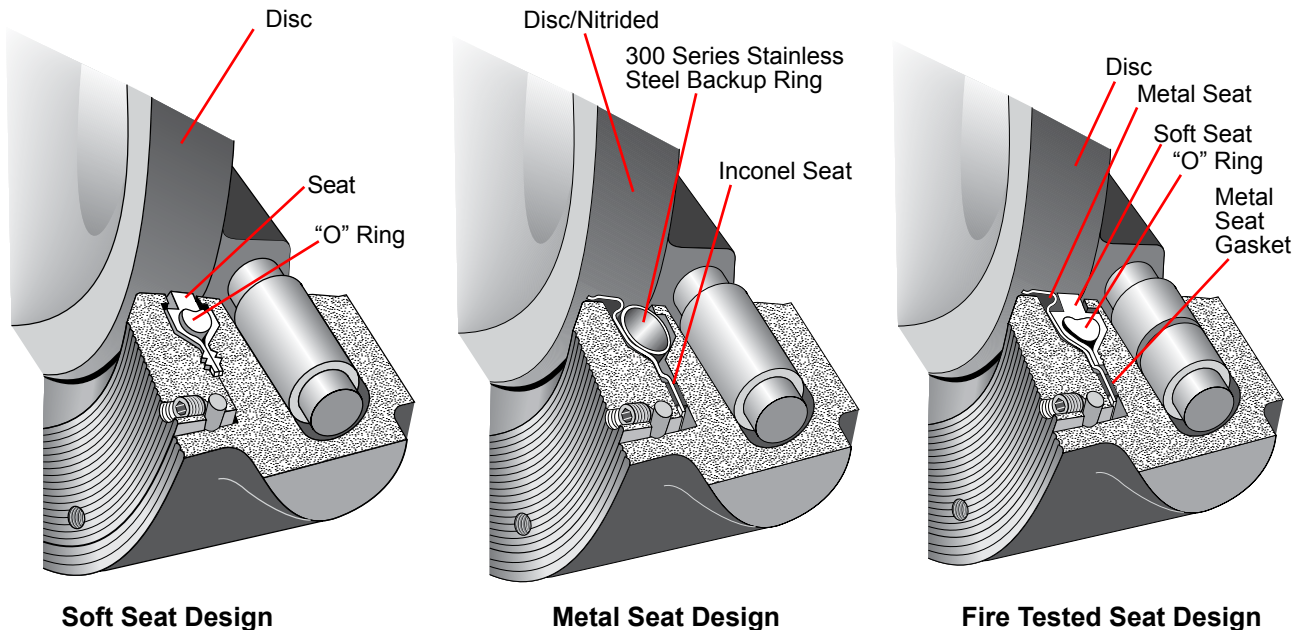

© Copyright Xomox Corporation 1980, 2009.
All rights reserved. Xomox®, Tuflin®, and Matryx®
are registered trademarks of Xomox Corporation.
XRP™ is a trademark of Xomox Corporation.

Soft Seat

Principle of Seat Sealing

DISC OPEN

In Figure 1, the disc and seat are not engaged. In this position, the shoulders of the seat are forced against the cavity shoulders by the compression of the o-ring.

The seat is recessed inside the seat cavity and acts as a gasket in the anchoring groove area. The seat cavity is sealed from exposure from the process fluid and protects the seat from abrasion and wear. The o-ring, which is completely encapsulated by the seat, is also isolated from exposure to the process fluid.

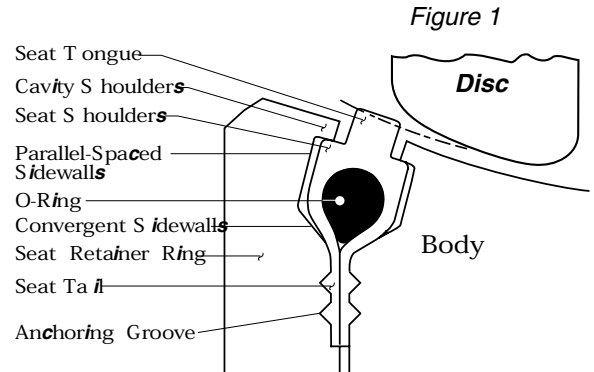

DISC CLOSED, Self-Energized Seal

In Figure 2, the disc and seat are engaged, and the process fluid is under low pressure. The edge of the disc, with a larger diameter than the seat tongue, directs movement of the seat radially outward, causing the seat to compress against the convergent sidewalls of the cavity. The elastomeric o-ring imparts a mechanical pre-load between the disc and seat tongue as it is compressed and flattened by the disc; this is the self-energized mode for sealing at vacuum-to-60 psig.

As the seat moves radially outward, the seat shoulders move away from the cavity shoulders and open the cavity to the process media.

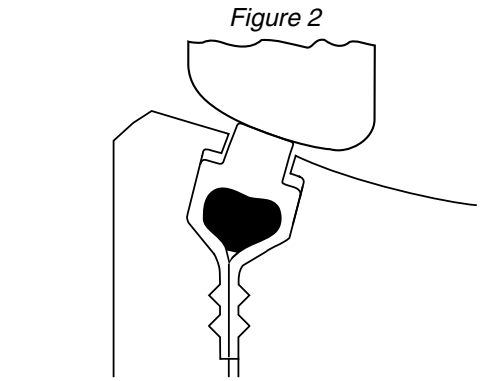

DISC CLOSED, Pressure-Energized Seal (Seat Upstream)

As line pressure increases, the process fluid enters the sidewall area and applies a load against the parallel-spaced sidewall and convergent sidewall of the seat. The seat and cavity design permits the seat to move axially to the downstream sidewall, but confines the movement and directs the movement radially inward towards the disc; the higher the line pressure, the tighter the seal between the disc and seat. Because the o-ring is elastic, it is able to flex and deform under loads and return to original shape after removal of the load; it is the rubber which deforms, not the thermoplastic material.

This dynamic seal is totally unique among high performance butterfly valves.

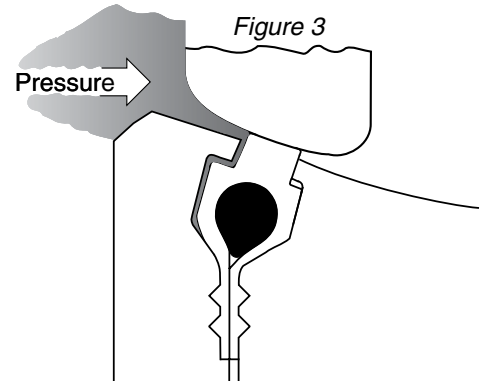

DISC CLOSED, Pressure-Energized Seal (Seat Downstream)

The valve is bi-directional (in some instances, modifications may be required to operate this arrangement for dead end service). The cavity and seat sidewalls are symmetrically designed to permit, confine and direct movement of the seat to the disc to dynamically seal with line pressure in the reverse direction. The disc edge is the segment of a sphere, and the seat is angled towards the disc edge to seal with pipeline pressure in either direction.

Recommended installation direction is "SUS" (seat upstream), as in Figure 3.

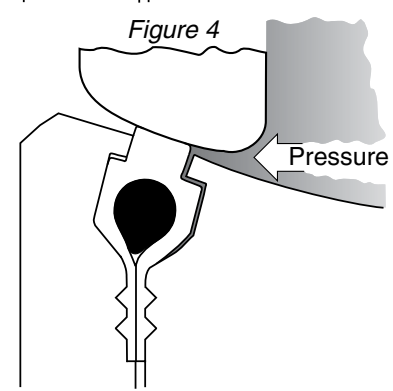

Soft Seat

Valve Components

KEY

Square key valve-to-operator connection provides an externally controlled failure point upon over-torquing

BLOW OUT PROOF SHAFT

Solid shaft provides alignment and rigid support for disc.

GRAND FLANGE

Applies load against packing gland to prevent external leakage. Fully adjustable.

PACKING GLAND

Separate part from gland flange, preventing uneven load distribution against packing.

PACKING

Chevron design PTFE prevents external leakage out valve neck to full ANSI hydrostatic shell test pressures (150% of C.W.P.)

BEARINGS

Both above and below the disc, bearings are of composite design; PTFE bonded to epoxy-glass filament wound ring. Used to align shaft, with high capacity, low wear, and low friction coefficient.

WEDGE RING

Stainless steel band wedged between valve body and retainer ring by set screws to lock seat and retainer ring in position on the 30" valve size. Socket head cap screws are used on valve sizes 36" and larger.

SET SCREWS

Cone point screws force wedge ring outward to lock seat retainer in position on the 30" valve size. Socket head cap screws are used on valve sizes 36" and larger.

WEDGE PINS

Provide positive mechanical attachment of disc to shaft.

OVERTRAVEL STOP

Prevents disc from rotating into the wrong quadrant.

BODY

ANSI B16.34 design in either wafer or lug configuration.

DISC

360° uninterrupted spherical edge for sealing. Profile is designed for maximum flow and equal percentage control.

SOFT-SEAT

Patented bi-directional seat with encapsulated elastomeric o-ring core for resiliency. Common seat materials include PTFE, RTFE and UHMWPE.

RETAINER RING

Retains seat in valve. Standard surface finish is 125 to 200 AARH and is compatible with both standard gaskets and spiral wound gasket designs. Outside diameter is recessed within gasket sealing surface to prevent external leakage.

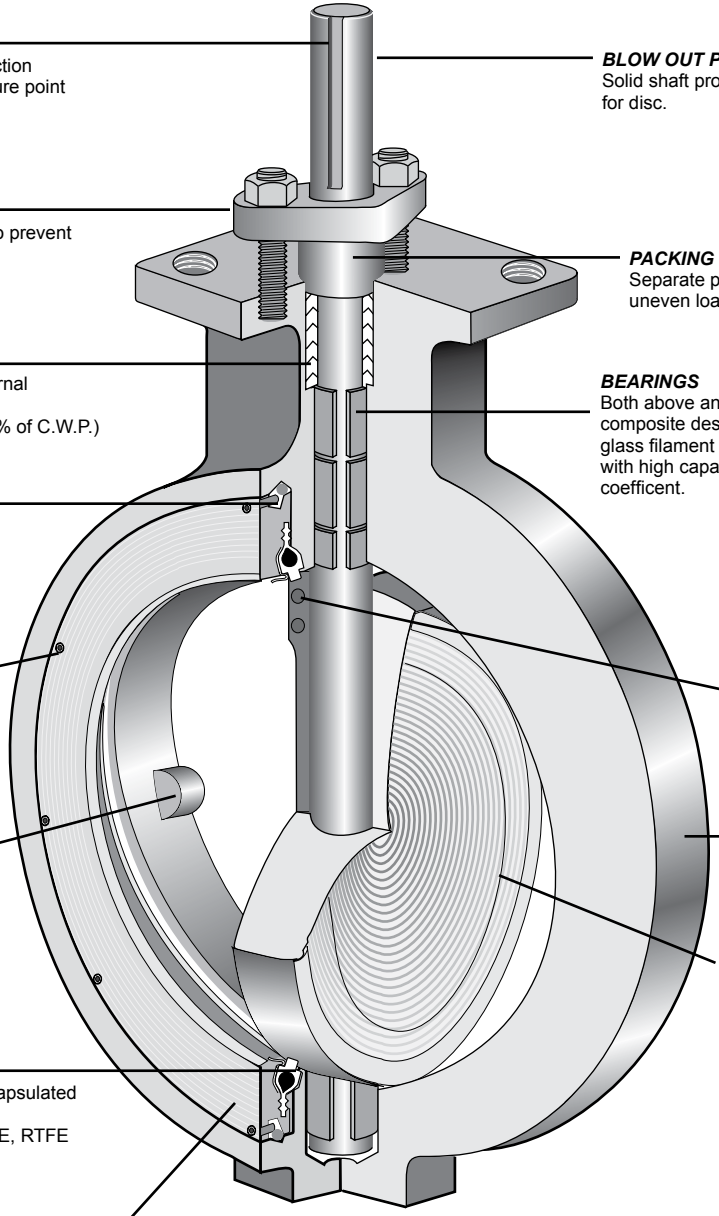

Lower Packing Variation

The ANSI 150 30" through 48"; ANSI 300 30"; sizes feature a two piece shaft design which utilizes a lower packing seal in the valve body to prevent external leakage. The component parts are of the same design used in the packing assembly in the top of valve body neck.

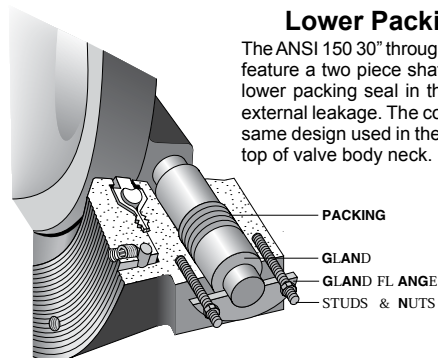

Soft Seat

Pressure/Temperature Ratings

PRESSURE/TEMPERATURE RATINGS

As temperature increases, the pressure retaining capability of materials decreases. The graph below illustrates the pressure/temperature ratings of ANSI Class 150 and Class 300 valves.

The heavy lines define the ratings of the carbon steel and stainless steel valve body (or "shell") in conformance to ANSI B16.34. The shaded areas define the ratings of the PTFE and RTFE Seat materials.

Seat ratings are based on differential pressure with the disc in the fully closed position.*

Steam Service

PTFE seated valves are rated for 50 psi saturated steam.

Valves with "O" seat configuration (RTFE seat / AFLAS O ring) are rated to 100 psi steam service.

ANSI B16.34 Body and Soft Seat Pressure - Temperature Ratings

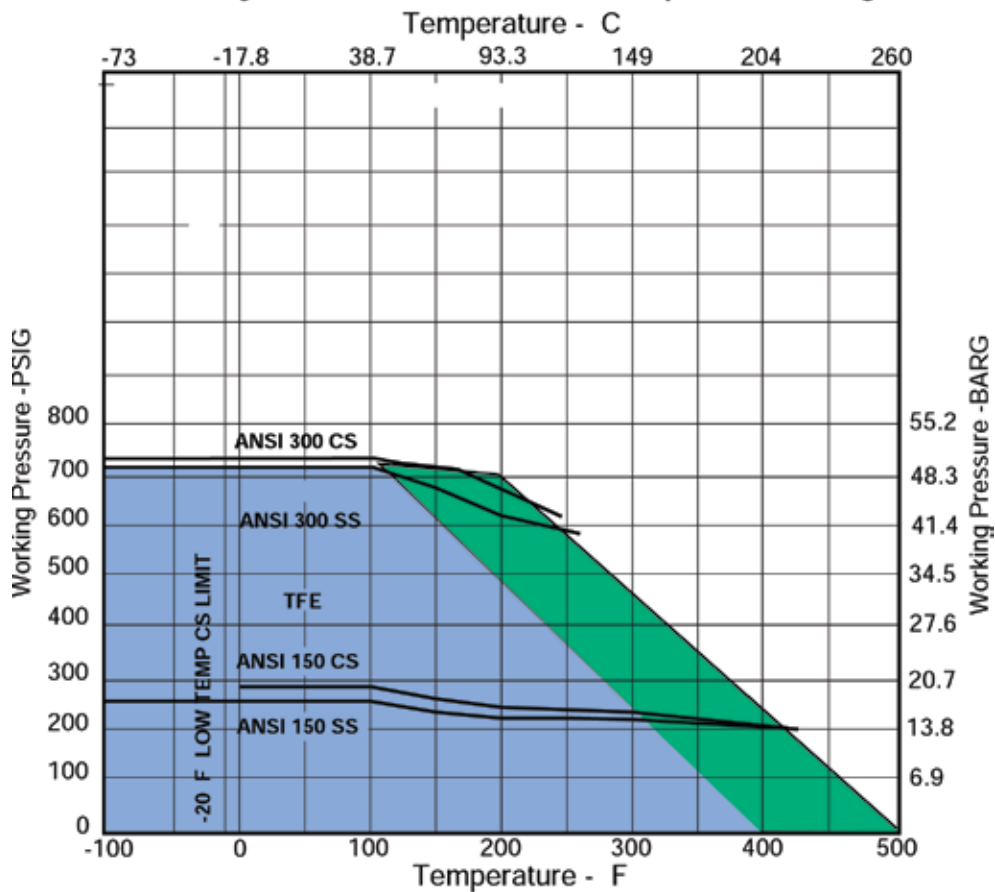

*Valves with 316 SS shafts are rated for maximum pressure differentials of 150 psi for Class 150 valves and 300 psi for Class 300 valves.

Metal Seat

Principles of Seat Sealing

PRINCIPLE OF METAL SEATING

Metal-to-metal sealing is accomplished by the "line contact" between a spherical surface and conical surface. Figure 1 illustrates a typical globe control valve seat and plug. The plug seating surface is the segment of a sphere; when engaged against the seat ring, a line contact seal is achieved.

In a metal seat design, it is necessary to apply enough force per linear inch to maintain a tight metal-to-metal contact between the sealing members; however, high linear thrust can cause a collapse of the seating members ("bearing failure").

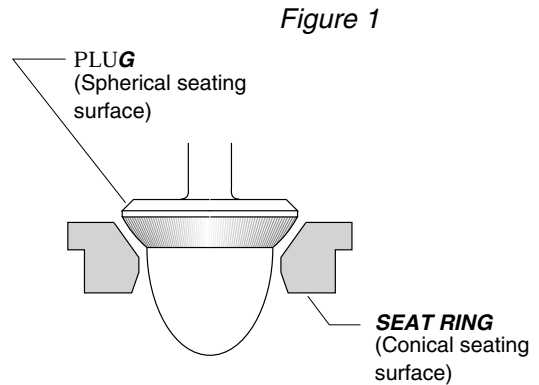

DISC CLOSED, Self-Energized Seal

In Figure 2, the disc and seat are engaged, and the process fluid is under low pressure. The spherical edge of the disc, with a larger diameter than the conical seat tongue, imparts a thrust of approximately 600 pounds per linear inch against the seat. The mechanical properties and shape of the Inconel seat allow it to both flex and maintain a constant thrust against the disc.

This controlled loading prevents the occurrence of bearing failure and reduces the leakage and wear between the components.

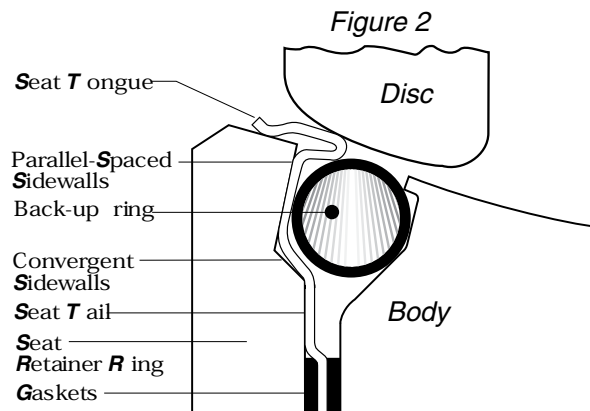

DISC CLOSED, Pressure-Energized Seal (Seat Upstream)

As line pressure increases, the process fluid enters the sidewall area and applies a load against the parallel-spaced sidewall and convergent sidewall of the metal seat. The seat moves towards the downstream sidewall while being supported axially by the support ring, as shown in Figure 3. The cavity shape confines the seat movement and directs the movement radially inward towards the disc; the higher the line pressure, the tighter the line contact between the disc and seat. The Inconel seat, shaped by a special hydroforming process, is able to flex under these loads and return to its original shape after removal of the loads.

This dynamic seal is totally unique among high performance butterfly valves.

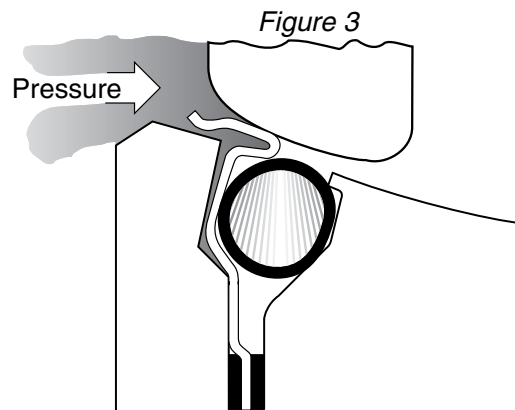

DISC CLOSED, Pressure-Energized Seal (Seat Downstream)

The valve is bi-directional (in some instances, modifications may be required to operate this arrangement for dead end service). The cavity and seat sidewalls are symmetrically designed to permit, confine and direct movement of the seat to the disc to dynamically seal with line pressure in the seat downstream direction, as in Figure 4. Recommended installation direction is "SUS" (seat upstream), as in Figure 3.

The stainless steel back-up ring interacts dynamically with the metal seat for axial support in seat sealing. Additionally, this ring effectively restricts corrosion and particulate build-up in the cavity.

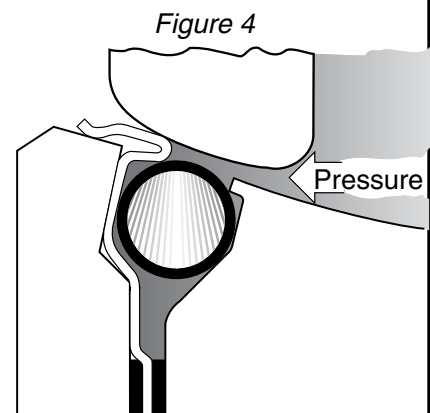

Valve Components

Metal Seat

KEY

Square key valve-to-operator connection provides an externally controlled failure point upon over-torquing.

GLAND FLANGE

Applies load against packing gland to prevent external leakage. Fully adjustable.

PACKING

Common materials are PTFE for up to 450 °F and Graphite for up to 900 °F.

WEDGE RING

Stainless steel band wedged between valve body and retainer ring by set screws to lock seat and retainer ring in position on the 30" valve size. Socket head cap screws are used on valve sizes 36" and larger.

WEDGE PINS

Provide positive mechanical attachment of disc to shaft.

OVERTRAVEL STOP

Prevents disc from rotating into wrong quadrant.

SET SCREWS

Cone point screws force wedge ring outward to lock seat retainer in position on the 30" valve size. Socket head cap screws are used on valve sizes 36" and larger.

METAL SEAT

Patented metal seat with metal back-up ring.

SHAFT

Solid shaft provides alignment and rigid support for disc.

PACKING GLAND

Separate part from gland flange, preventing uneven load distribution against packing.

BEARINGS

Both above and below the disc, bearings maintain shaft alignment. Common materials include:

- Glass-backed PTFE for up to -450 °F. (Not for steam service.)
- Lubrized Bronze for up to 750 °F.
- 300 Series Stainless Steel Nitrided for up to 900 °F.

BODY

ANSI B16.34 design in either wafer or lug configuration.

DISC

360° uninterrupted spherical edge for sealing. Profile is designed for maximum flow and equal percentage control. Disc seating surface is Nitrited for enhanced temperature and abrasion resistance.

RETAINER RING

Retains seat in valve. Standard surface finish is 125 to 250 AARH and is compatible with both standard gaskets and spiral wound gasket designs. Outside diameter is recessed within gasket sealing surface to prevent external leakage.

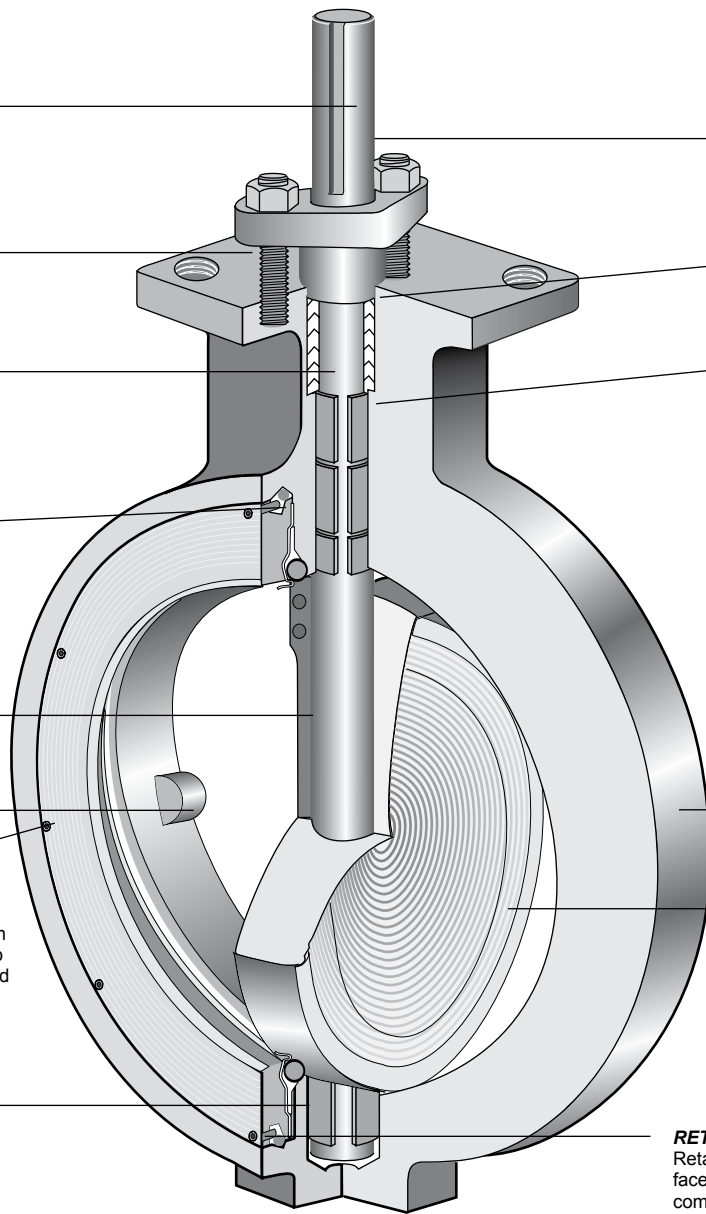

Lower Packing Variation

The ANSI 150 30" through 48"; ANSI 300 30" sizes feature a two-piece shaft design which utilizes a lower packing seal in the valve body to prevent external leakage. The component parts are of the same design used in the packing assembly in the top of the valve body neck.

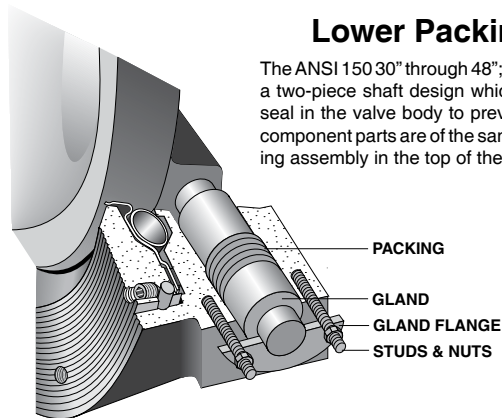

Metal Seat

Pressure/Temperature Ratings

PRESSURE/TEMPERATURE RATINGS

As temperature increases, the pressure retaining capability of materials decreases. The graph below illustrates the pressure/temperature ratings of ANSI Class 150 and Class 300 valves.

The heavy lines define the ratings of the carbon steel and stainless steel valve body (or "shell") in conformance to ANSI B16.34. The shaded areas define the ratings of the metal seat.

Seat ratings are based on differential pressure with the disc in the fully closed position.

ANSI B16.34 Body and Metal Seat Pressure - Temperature Ratings
Temperature - C

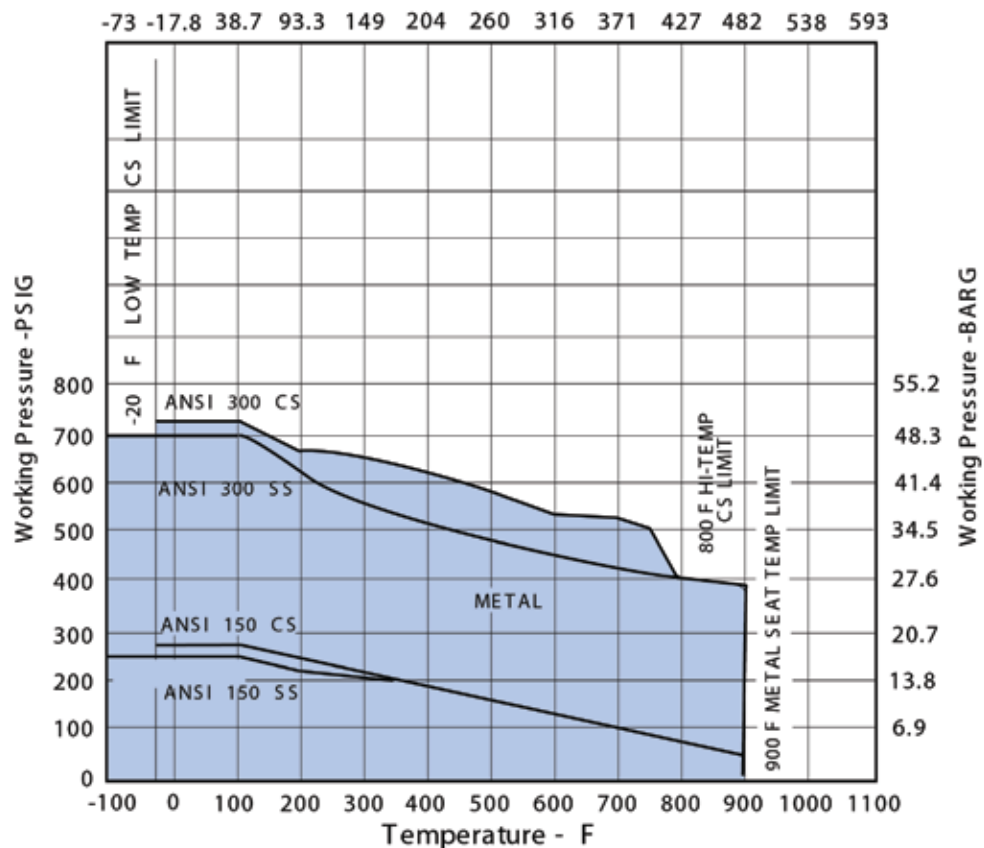

Fire-Tested Seat Principle of Seat Sealing

DISC OPEN, Normal Operation

In Figure 1, the disc and seat assembly are not engaged. In this position, the metal seat acts to keep the soft seat inside the seat cavity while the soft seat shoulders seal the cavity from exposure to the process fluid. (The o-ring is under tension and imparts a load against the soft seat.)

The soft seat is protected from abrasion and wear because it is recessed inside the seat cavity area. The o-ring is isolated from exposure to the fluid because it is completely encapsulated by the seat tails which act as a (soft) gasket in the anchoring groove area. The metal seat gaskets add further high temperature protection past the anchoring grooves.

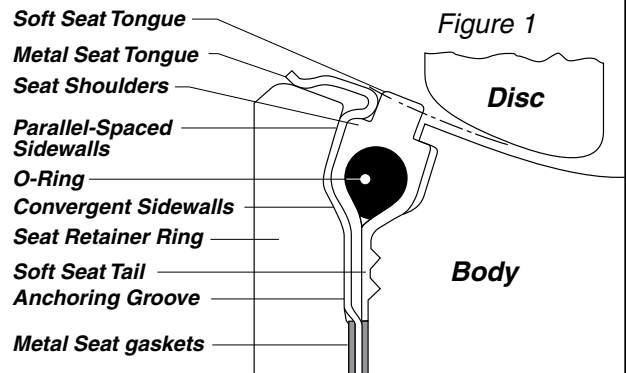

DISC CLOSED, Normal Operation

In Figure 2, the disc and seat assembly are engaged; both the metal seat and the soft seat are in contact with the disc. Under little to no pressure conditions, both seats are self-energized. The disc edge, with a larger diameter than the seat tongues, moves the seats radially outward; the metal seat shape, with a mechanical and dynamic flexibility, is designed to be hoop-loaded and impart a spring force against the disc, while the soft seat o-ring is stretched and flattened (without deformation of the material) and imparts a mechanical pre-load against the disc.

With increased line pressure, the process fluid enters the cavity sidewall area and applies loads against the seat sidewalls. The cavity design allows the seats to move toward the downstream sidewalls, but confines and directs the movement radially inward towards the disc; the higher the pressure the tighter the seal. The symmetrical shape and angle of the cavity permit the seal to be bi-directional.

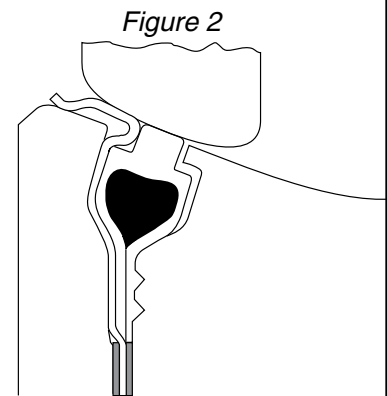

DISC CLOSED, After Fire (Seat Upstream)

After a fire, with partial or complete destruction of the soft seat, the metal seat maintains metal-to-metal contact with the disc and restricts leakage of the process fluid in conformance to industry fire-safe requirements.

With little or no line pressure, the spring force and hoop load of the metal seat maintain a "line contact" seal against the disc edge. Under higher pressures, the process fluid enters the cavity sidewall areas and applies loads against the seat sidewalls (Figure 3). The geometry of the metal seat permits the seat to move axially, but directs the movement radially inward toward the disc; The higher the pressure, the tighter the line contact seal.

Graphite gaskets, on both sides of the metal seat tail, seal the anchoring groove and prevent leakage of the process fluid.

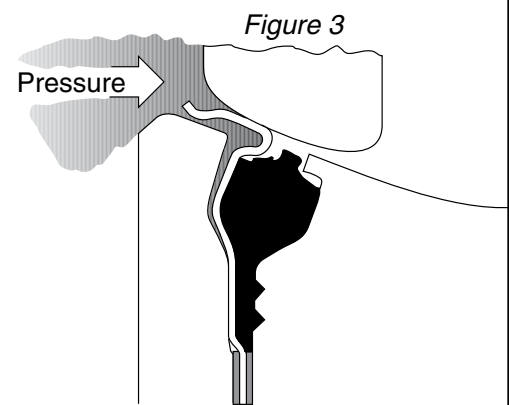

DISC CLOSED, After Fire (Seat Downstream)

The fire tested valve is bi-directional, however, modifications are required to operate for bi-directional dead end service. The angle and shape of the cavity and metal seat maintains metal-to-metal contact in the event of partial or complete soft seat destruction with line pressure in the reverse direction (Figure 4).

While the preferred flow direction is "seat upstream" (SUS), the bi-directional seat design is both self-energized and pressure-energized if the flow direction is "seat downstream" (SDS).

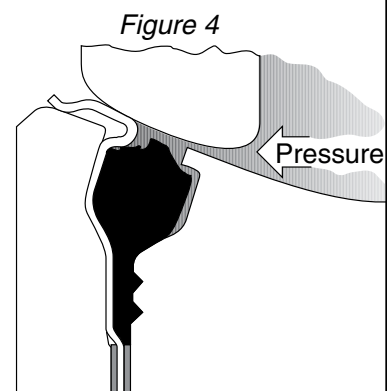

Fire-Tested Seat

Valve Components

KEY

Square key valve-to-operator connection provides an externally controlled failure point upon over-torquing

GRAND FLANGE

Applies load against packing gland to prevent external leakage. Fully adjustable.

PACKING

Common material is graphite.

RETAINER RING

Retains seat in valve. Standard surface finish is 125 to 200 AARH and is compatible with both standard gaskets and spiral wound gasket designs. Outside diameter is recessed within gasket sealing surface to prevent external leakage.

OVERTRAVEL STOP

Prevents disc from rotating into the wrong quadrant.

SET SCREWS

Cone point screws force wedge ring outward to lock seat retainer in position on the 30" valve size. Socket head cap screws are used on valve sizes 36" and larger.

WEDGE RING

Stainless steel band wedged between valve body and retainer ring by set screws to lock seat and retainer ring in position on the 30" valve size. Socket head cap screws are used on valve sizes 36" and larger.

SHAFT

Solid shaft provides alignment and rigid support for disc.

PACKING GLAND

Separate part from gland flange, preventing uneven load distribution against packing.

OUTER BEARINGS

Stainless steel back-up bearings maintain shaft alignment after a fire. (Both above and below disc.)

INNER BEARINGS

Both above and below the disc, bearings are of composite design. PTFE bonded to epoxy-glass filament wound ring. Used to align shaft, with high load capacity, low wear and low friction coefficient.

WEDGE PINS

Provide positive mechanical attachment of disc to shaft.

BODY

ANSI B16.34 design in either wafer or lug configuration.

DISC

Fire-Flow disc is electroless nickel plated for enhanced temperature and abrasion resistance.

FIRE TESTED SEAT

Patented bi-directional soft seat design for zero-leakage in normal operation and a metal-to-metal seal after a fire, meeting or exceeding industry "fire-safe" specifications.

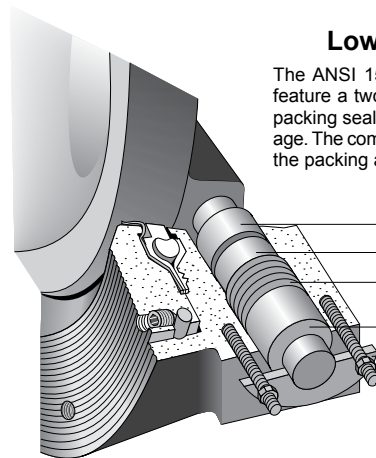

Lower Packing Variation

The ANSI 150 30" through 48"; ANSI 300 30" sizes feature a two piece shaft design which utilizes a lower packing seal in the valve body to prevent external leakage. The component parts are of the same design used in the packing assembly in the top of valve body neck.

INNER BEARING

OUTER BEARING

PACKING

GLAND

GLAND FLANGE

STUDS & NUTS

Fire-Tested Seat

Pressure/Temperature Ratings

PRESSURE/TEMPERATURE RATINGS

As temperature increases, the pressure retaining capability of materials decreases. The graph below illustrates the pressure/temperature ratings of ANSI Class 150 and Class 300 valves.

The heavy lines define the ratings of the carbon steel and stainless steel valve body (or “shell”) in conformance to ANSI B16.34. The shaded areas define the ratings of the soft seat.

Seat ratings are based on differential pressure with the disc in the fully closed position.

ANSI B16.34 Body and Soft Seat Pressure - Temperature Ratings

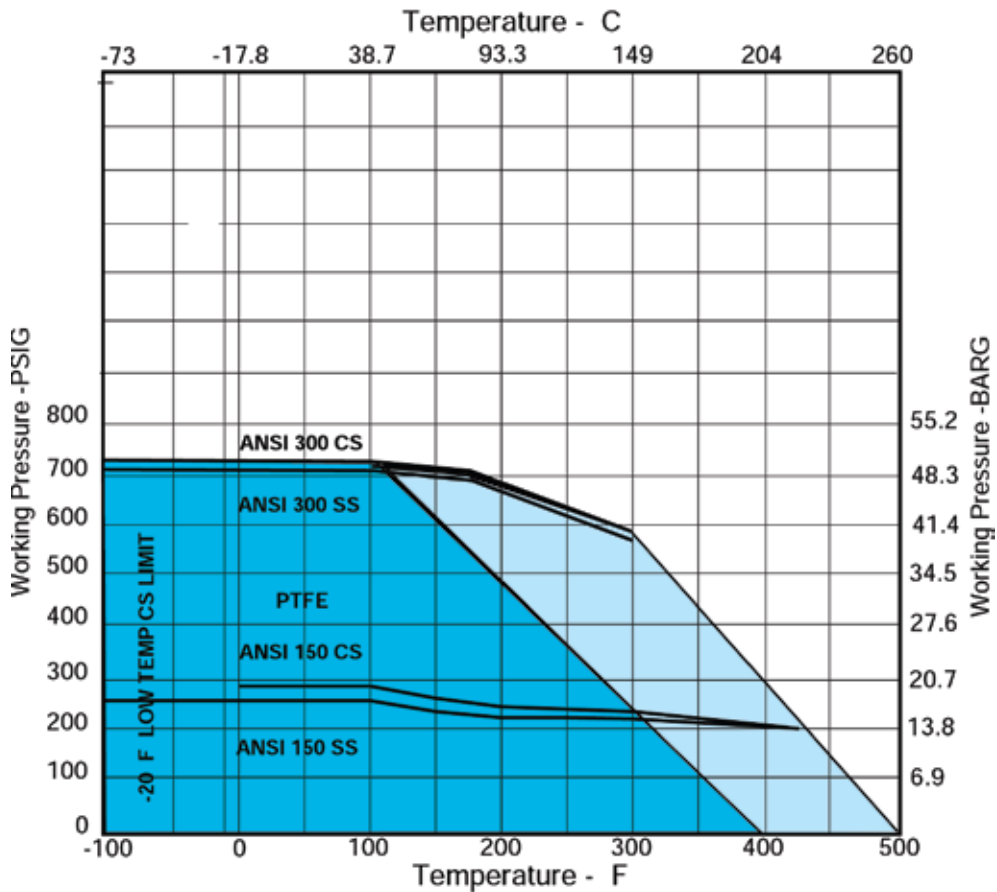

Valve Dimensions

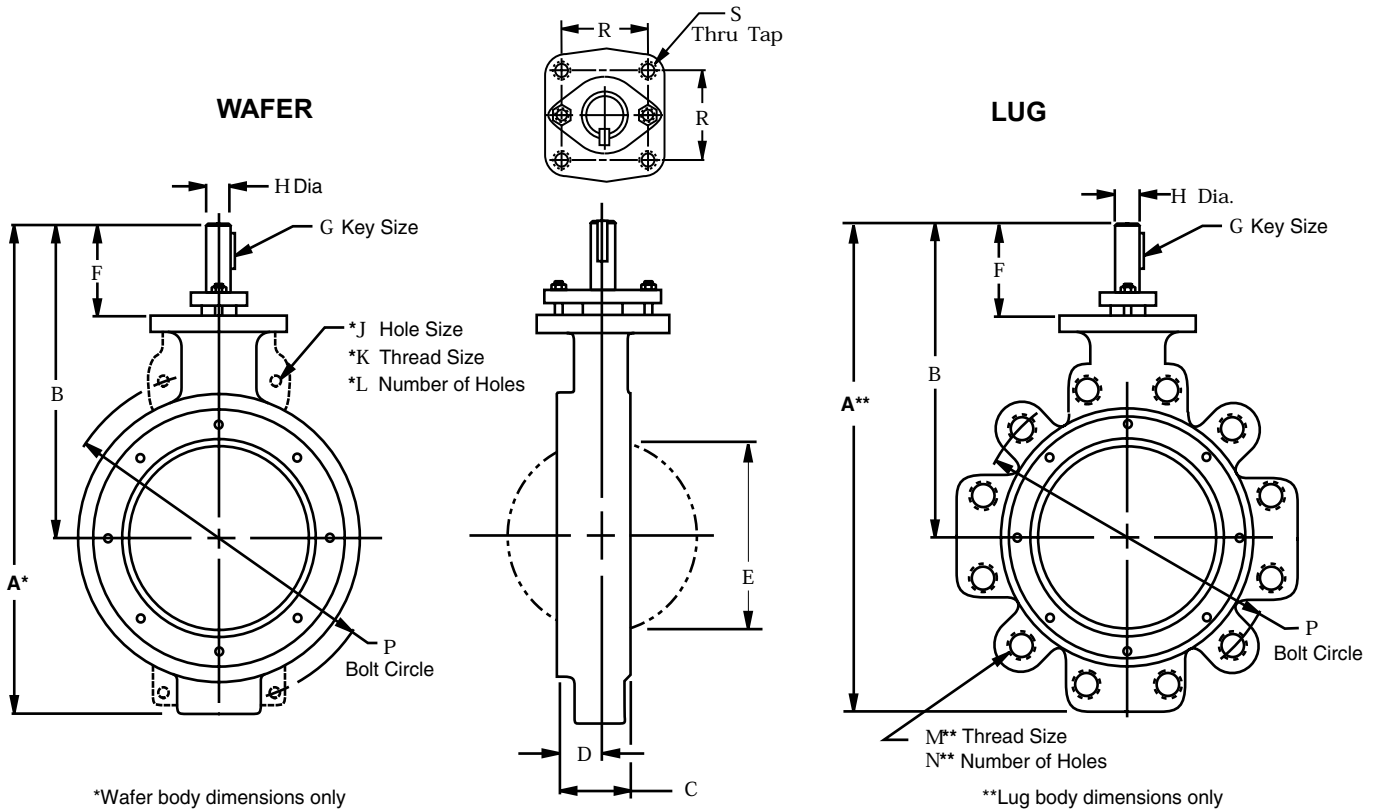

ANSI Class 150

VALVE SIZE	WAFER	LUG	B	C	D	E	F	G	H	J*	K*	L*	M**	N**	P	R	S	WEIGHT (LBS)	
	A*	A**																WAFER	LUG
30"	52.08	52.08	29.35	6.75	3.53	28.00	8.73	3/4	3.000	-	11 4-8	4	11 4-8	28	36.000	5.000	3 4-10	925	1130
36"	64.75	64.75	32.64	8.38	4.34	33.66	8.14	1	3.750	-	11 2-8	4	11 2-8	32	42.75	7.00	1-8	1630	1890
42"	73.24	73.24	37.62	9.25	5.03	40.31	9.62	1	4.500	-	11 2-8	4	1 2-8	36	49.500	7.00	1-8	2475	2700
48"	80.13	80.13	41.88	10.62	5.62	45.25	10.63	1 4	5.000	-	11 2-8	4	11 2-8	44	56	9.00	1-8	2815	3085

ANSI Class 300

VALVE SIZE	WAFER	LUG	B	C	D	E	F	G	H	J*	K*	L*	M**	N**	P	R	S	WEIGHT (LBS)	
	A*	A**																WAFER	LUG
30"	62.40	62.40	31.90	8.88	4.39	27.25	9.02	1	4.500	-	13/4-8	4	13/4-8	28	39.250	7.00	1-8	1745	2145

NOTES

1. General

- Standard valves tested to MSS-SP--61. API-598 testing available upon request.
- Valves for installation between DIN and JIS flanges available on application.
- Dimensions shown are for reference only. Certified drawings available on application.
- Valves are designed for installation between MSS-SP-44 flanges.

Valve Flow Coefficients

C_v FACTORS

C_v (Coefficient of Volume) is the number of U.S. gallons per minute of water required to pass through a valve with a pressure drop of 1 psi. The chart below records this C_v factor for the Tuflin valve classes and sizes at ten degree increments between open and closed. The values shown are for the valve installed in the seat upstream ("SUS") position.

Degree Open % Full C _v	10° 1.5%	20° 6%	30° 14%	40° 25.2%	50° 38%	60° 55%	70° 75%	80° 97%	90° 100%
30" 150	491	1965	4585	8253	12445	18012	24563	32750	34388
300	404	1614	3766	6779	10222	14795	20175	26900	28245
36" 150	707	2830	6602	11884	17920	25938	35370	45745	47160
42" 150	963	3851	8987	16176	24392	35304	48143	62264	64190
48" 150	1258	5030	11738	21128	31859	46111	62881	81324	83840

C_f FACTORS

The critical flow factor, C_f, expresses the valve pressure recovery ratio. It is equivalent to F_L in ISA nomenclature.

DISC DEGREE OPENING	15°	20°	25°	30°	35°	40°	45°	50°	55°	60°	65°	70°	75°	80°	85°	90°
SEAT UPSTREAM	.95	.91	.84	.81	.78	.80	.77	.74	.74	.73	.70	.66	.63	.60	.57	.53
SEAT DOWNSTREAM	.94	.89	.84	.82	.80	.77	.75	.72	.69	.66	.63	.60	.58	.55	.54	.53

Valve Torque Values

TUFLINE High Performance Butterfly Valve Eccentric Shaft Design

In the SUS position (preferred pipeline flow direction), the line pressure tends to assist in opening the valve disc. In the SDS position, the line pressure tends to assist in keeping the valve disc closed; also, line pressure acting on the surface of the disc creates more mechanical pre-load between the disc and seat. Therefore, SDS torque values are higher than SUS values.

ANSI Class 150

SEATING and UNSEATING TORQUE VALUES (All torques are in Inch Pounds)

VALVE SIZE	SOFT SEAT			
	SEAT UPSTREAM (SUS)		SEAT DOWNSTREAM (SDS)	
	0-150 PSIG	285 PSIG	0-150 PSIG	285 PSIG
30"	32330	56930	45500	71800
36"	47000	81000	66000	102000
42"	65000	111000	92000	140000
48"	83000	146000	115000	184000

VALVE SIZE	FIRE TESTED SEAT			
	SEAT UPSTREAM (SUS)		SEAT DOWNSTREAM (SDS)	
	0-150 PSIG	285 PSIG	0-150 PSIG	285 PSIG
30"	61200	89800	86100	113300
36"	C.F.	C.F.	C.F.	C.F.
42"	C.F.	C.F.	C.F.	C.F.

VALVE SIZE	METAL SEAT			
	SEAT UPSTREAM (SUS)		SEAT DOWNSTREAM (SDS)	
	0-150 PSIG	285 PSIG	0-150 PSIG	285 PSIG
30"	80500	115000		
36"	C.F.	C.F.		
42"	C.F.	C.F.		

Torques shown are for on/off applications and include sizing margins appropriate to normal liquid and gas applications. For severe services, or unusual fluids or slurries, consult factory.

Valve Torque Values

ANSI Class 300

SEATING and UNSEATING TORQUE VALUES (All torques are in Inch Pounds)

VALVE SIZE	SOFT SEAT											
	SEAT UPSTREAM (SUS)						SEAT DOWNSTREAM (SDS)					
	0-150 PSIG	285 PSIG	400 PSIG	500 PSIG	600 PSIG	700 PSIG	0-150 PSIG	285 PSIG	400 PSIG	500 PSIG	600 PSIG	700 PSIG
30"	35920	63620	88430	109620	125290	156780	80000	110000	13500	155000	182000	200000

VALVE SIZE	FIRE TESTED SEAT											
	SEAT UPSTREAM (SUS)						SEAT DOWNSTREAM (SDS)					
	0-150 PSIG	285 PSIG	400 PSIG	500 PSIG	600 PSIG	700 PSIG	0-150 PSIG	285 PSIG	400 PSIG	500 PSIG	600 PSIG	700 PSIG
30"	61200	89800	126320	156600	179000	224000	91800	125720	176850	219250	250600	313600

VALVE SIZE	METAL SEAT											
	SEAT UPSTREAM (SUS)						SEAT DOWNSTREAM (SDS)					
	0-150 PSIG	285 PSIG	400 PSIG	500 PSIG	600 PSIG	700 PSIG	0-150 PSIG	285 PSIG	400 PSIG	500 PSIG	600 PSIG	700 PSIG
30"	112000	131000	164000	193000	Consult Factory		Consult Factory					

Materials of Construction

Carbon Steel Construction

COMPONENTS	-20 °F to 450 °F	451 °F to 750 °F	751 °F to 800 °F
BODY	Carbon Steel A216 Gr WCB	Carbon Steel A216 Gr WCB	Carbon Steel A216 Gr WCB
DISC	316 Stainless Steel A351 CF8M	316 Stainless Steel A351 CF8M Nitrided	316 Stainless Steel A351 CF8M Nitrided
SHAFT & PINS	17-4 PH Stainless Steel A564 Gr 630	17-4 PH Stainless Steel A564 Gr 630	17-4 PH Stainless Steel A564 Gr 630
SEAT	PTFE or Inconel	Inconel	Inconel
PACKING	PTFE	Graphite	Graphite
BEARINGS	Glass-Backed PTFE	Bronze	316 Stainless Steel Nitrided

Stainless Steel Construction

COMPONENTS	-100 °F to 450 °F	451 °F to 750 °F	751 °F to 900 °F
BODY	316 Stainless Steel A351 CF8M	316 Stainless Steel A351 CF8M	316 Stainless Steel A351 CF8M
DISC	316 Stainless Steel A351 CF8M	316 Stainless Steel A351 CF8M Nitrided	316 Stainless Steel A351 CF8M Nitrided
SHAFT & PINS	17-4 PH Stainless Steel A564 Gr 630	17-4 PH Stainless Steel A564 Gr 630	316 Stainless Steel* A479 Gr 316
SEAT	PTFE or Inconel	Inconel	Inconel
PACKING	PTFE	Graphite	Graphite
BEARINGS	Glass-Backed PTFE	Bronze	316 Stainless Steel Nitrided

* Metal Seat Valves with 316 SS Shafts are rated for maximum pressure differentials of 150 psi for Class 150 and 300 psi for Class 300. Monel, Nitronic 50 and Inconel 718 or X750 shafts may be substituted for higher pressure differentials at elevated temperatures. Consult factory for additional information.

How To Specify

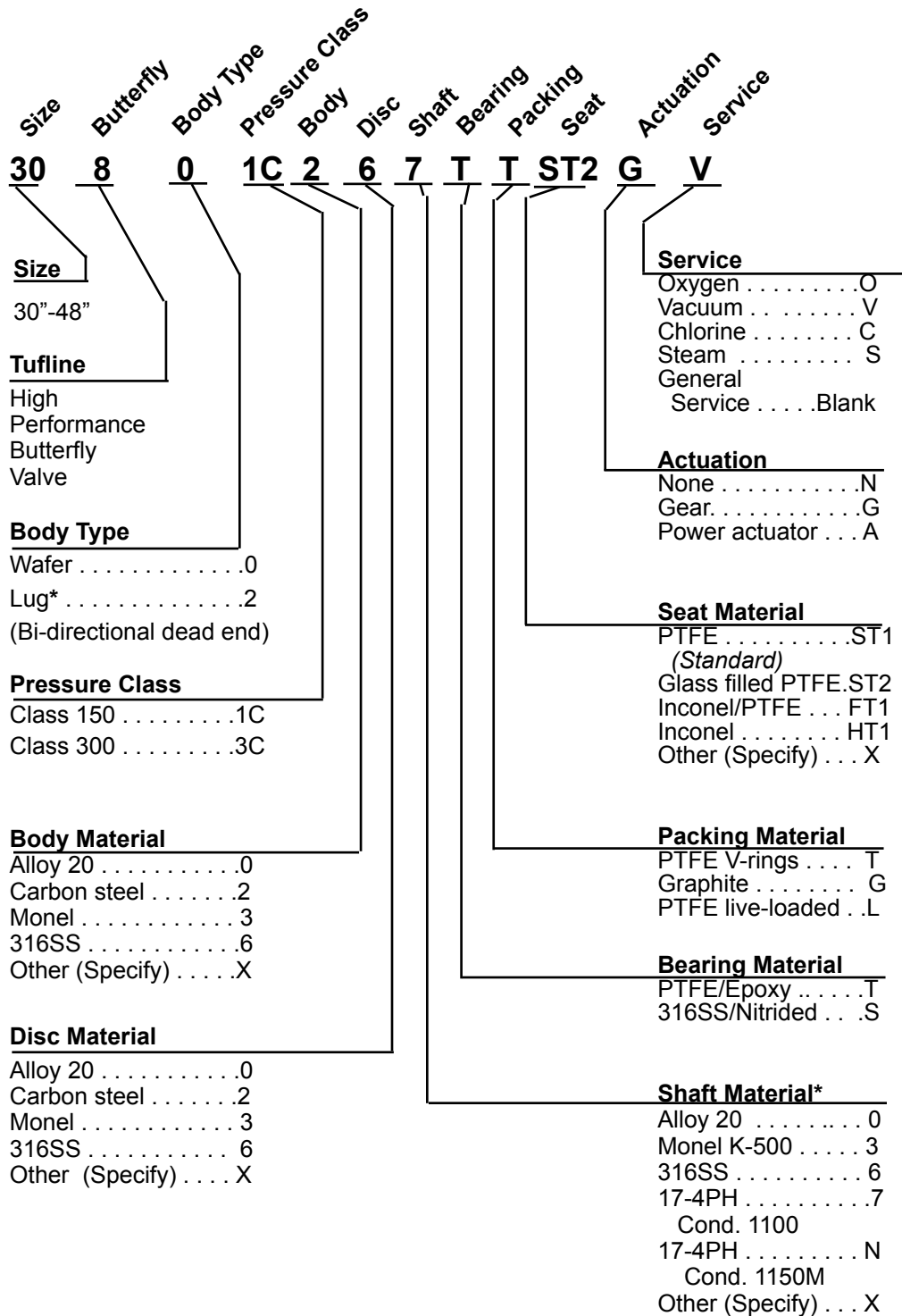

* Pressure differential is limited to 150 psi for Class 150 valves and 300 psi for Class 300 valves when used in dead end service with the seat downstream (SDS)

XOMOX®

CRANE ChemPharma Flow Solutions™

XOMOX Headquarters
4444 Cooper Road,
Cincinnati, OH 45242, U.S.A.
Tel.: (513) 745-6000
Fax: (513) 745-6086

XOMOX International GmbH & Co. OHG
Von-Behring-Straße 15,
D-88131 Lindau/Bodensee
Tel.: (49) 8382-702-0
Fax: (49) 8382-702-144

CRANE

ChemPharma Flow Solutions



brands you trust.

CRANE ChemPharma Flow solutions Include: Pipe - Valves - Fitting - Actuators - Pumps

DEPA®

PSI
LINE PIPE SYSTEMS

ResistoPure

Saunders®
the science inside

ELRO®

RESISTOFLEX®

revo®

XOMOX®

CP-XOMOX-HPBV-BU-EN-CL-7/09-PN335251

Crane Co., and its subsidiaries cannot accept responsibility for possible errors in catalogues, brochures, other printed materials, and website information. Crane Co. reserves the right to alter its products without notice, including products already on order provided that such alteration can be made without changes being necessary in specifications already agreed. All their trademarks in this material are property of the Crane Co. or its subsidiaries. The Crane and Crane brands logotype (Xomox®, Saunders®, Resistoflex®, Resistopure™, PSI®, DEPA®, ELRO®, REVO®) are registered trademarks of Crane Co. All rights reserved.